

- NOTES**
- THIS DRAWING TO BE READ IN CONJUNCTION WITH GENERAL STRUCTURAL NOTES DRAWING.
 - THE DETAILS SHOWN ON THIS DRAWING ARE BASED ON REQUIREMENTS OUTLINED IN A.S.1657 (S.A.A. CODE FOR FIXED PLATFORMS, WALKWAYS, STAIRWAYS AND LADDERS) AND ARE MINIMUM ACCEPTABLE.
 - THE TYPE AND EXTENT OF HANDRAILS IS SHOWN ON THE DESIGN DRAWINGS.
 - CONTACT SURFACES OF HANDRAILS SHALL BE SMOOTH AND FREE FROM BURRS AND SHARP CORNERS.
 - ALL HANDRAILS ON THIS DRAWING ARE MONOWILLS HANDRAILING.
 - ALL HANDRAIL STANCHIONS AND RAILING TO BE HOT DIPPED GALVANISED U.O.N.
 - TYPE 'P' STANCHIONS ARE NOT RECOMMENDED WHERE CUT-OUTS IN THE FLOORING ARE REQUIRED FOR STANCHION INSTALLATION.
 - IF BENT PIPE IS NOT CONTINUOUS THROUGH STANCHION BALL, USE SPLICE (DETAIL P) OR FULLY WELD PIPE TO STANCHION.

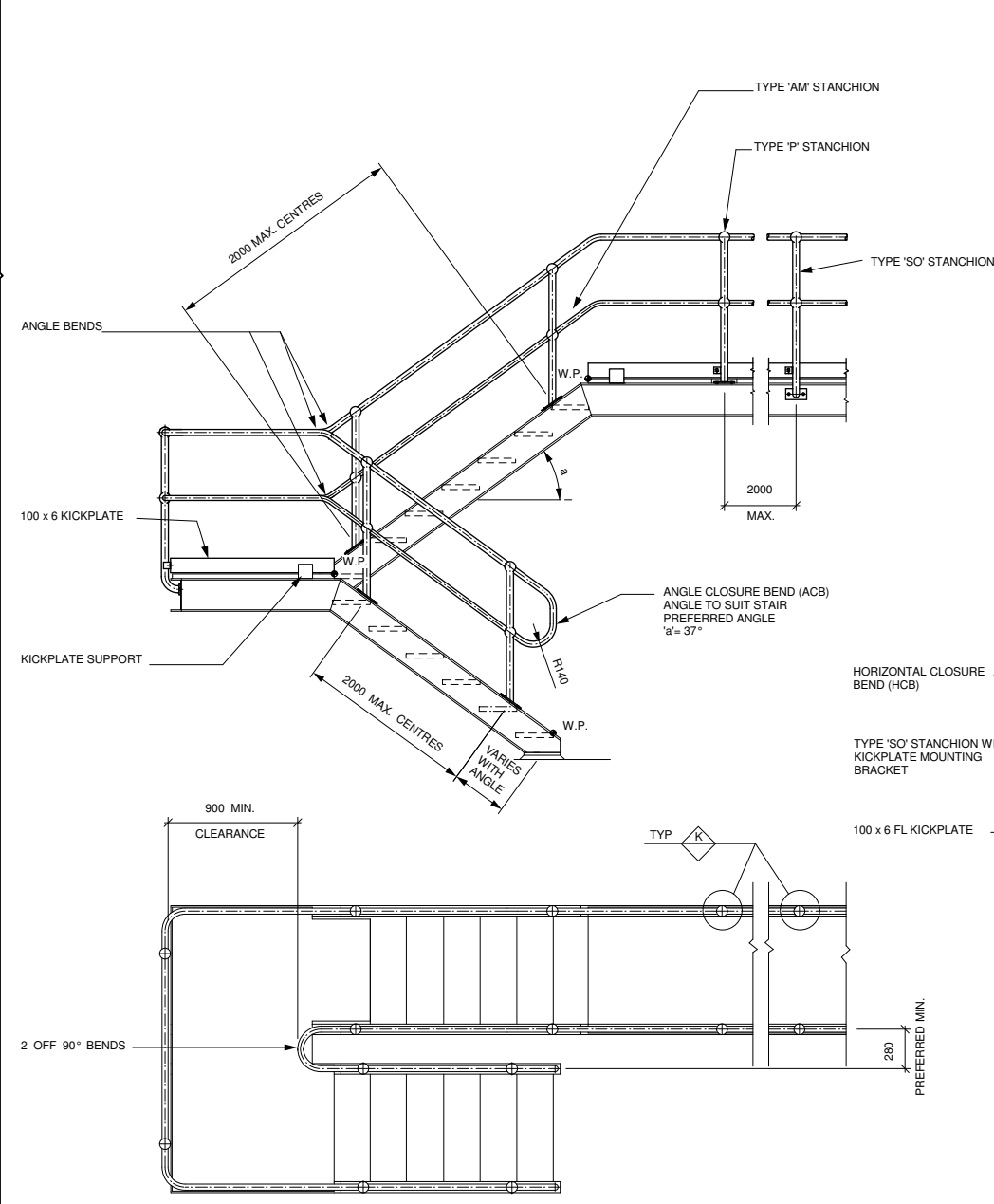

TYPICAL STAIR & PLATFORM HANDRAIL DETAILS

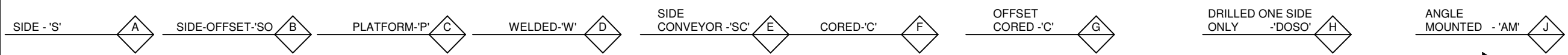
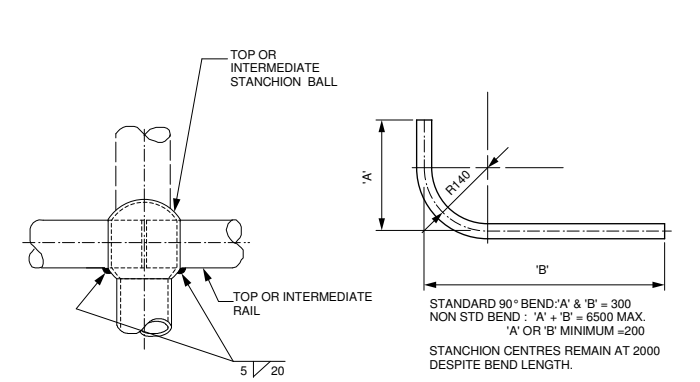

TYPICAL STANCHION/HANDRAIL JOINT (K)

TYPICAL 90° STD. & NON STD. BENDS SEE NOTE 8. (L)

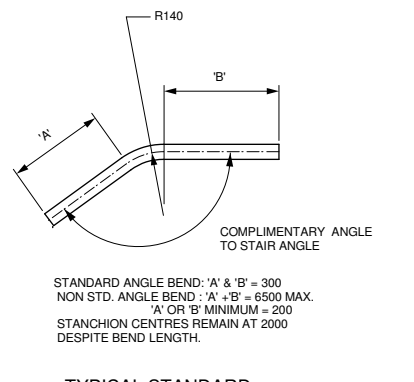

TYPICAL STANDARD & NON STANDARD ANGLE BENDS (M)

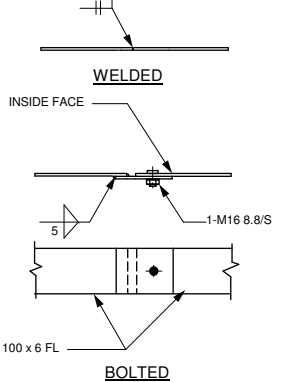

TYPICAL KICKPLATE SPLICE (N)

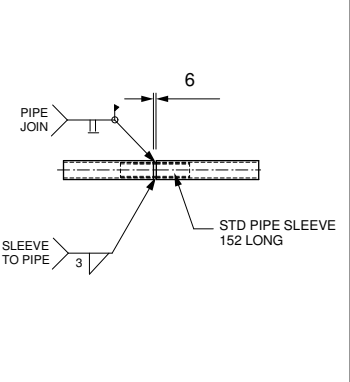

TYPICAL HANDRAIL SPLICE (P)

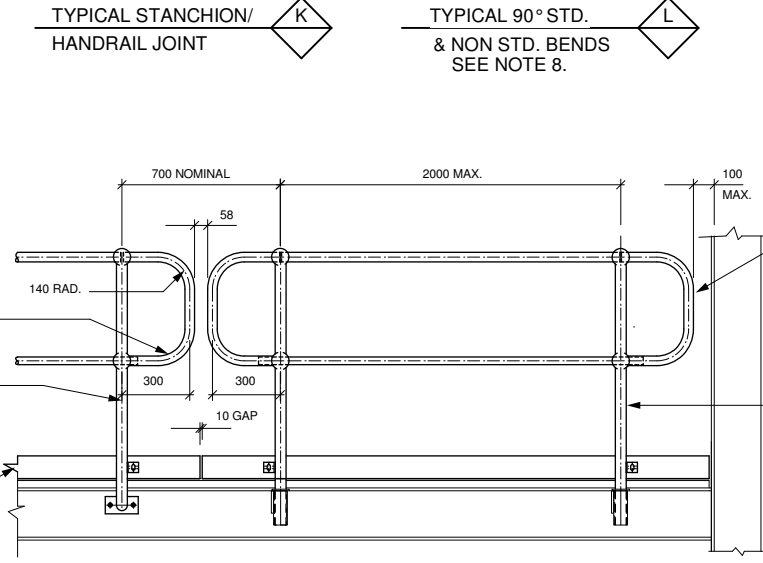

TYPICAL REMOVABLE PANEL (Q)

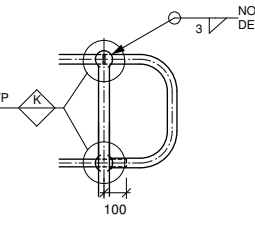

TYPICAL CLOSURE HANDRAIL JOINT (Q)

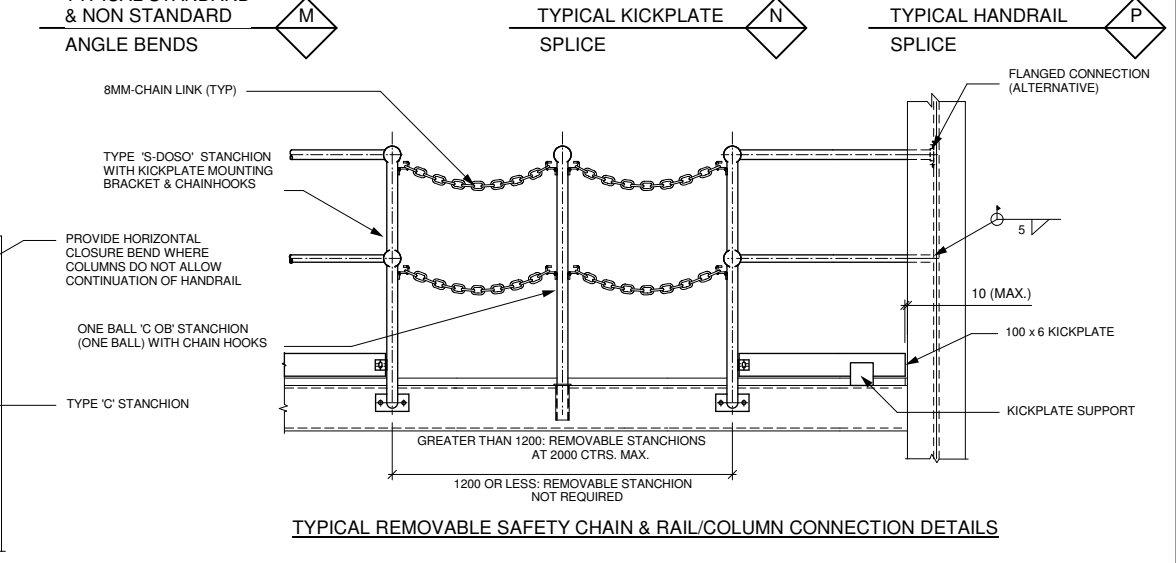

TYPICAL REMOVABLE SAFETY CHAIN & RAIL/COLUMN CONNECTION DETAILS

FOR GENERAL RELEASE

1	Q DETAIL, NOTE 8 & KP BRACKET	MR	01/08/07
0	RE-NUMBERED FROM STD-018r3	TW	19/5/05
REV	PARTICULARS	BY	DATE
WEBFORGE (WA) 24 TENANT STREET, WELSHPOOL WESTERN AUSTRALIA A.C.N. 009 419 756 Phone (08) 9361 8933 Fax (08) 9361 7057			
CLIENT: STANDARD HANDRAIL DETAILS			
DETAIL: MILD STEEL STANCHION WELDING			
WEBFORGE QRD TYPE	SURFACE TREATMENT	REQ'N No.	STD - 101/0
DRAWN TAW	CHK	CUST. QN.	DRAWING No. STD - 101
DATE 11/94	JOB No.		REV. 1